



Avantis 70

Windows and Doors

Sapa Building System



Avantis 70 is a high performance thermally broken three-chamber system with a building depth of 70 mm. The Avantis 70 largely surpasses the recent thermal insulation standards and is a comprehensive solution for commercial, residential and industrial projects.



Energy saving on modular basis

- » Avantis 70 profiles have 3 chambers, coupled with 35 mm omega shaped, glass fibre reinforced polyamide strips, which reduce thermal conduction. The result is that Avantis 70 achieves a high thermal performance level and improved total insulation, leading to lower total energy consumption, a positive benefit to the environment
- » The system accommodates glazing up to 55 mm for frame and 65 mm for vent, the infill thickness can start from 4,5 mm
- » Inward opening vents have a solid central gasket for enhanced thermal and acoustic performance
- » All standard shade and ventilation systems can easily be integrated in Avantis 70
- » Avantis 70 basic: profile combinations with value $U_f = 1,9 \text{ W/m}^2\text{K} - 2,8 \text{ W/m}^2\text{K}$
- » Avantis 70 i: profile combinations with value $U_f = 1,8 \text{ W/m}^2\text{K} - 2,2 \text{ W/m}^2\text{K}$
- » Avantis 70 si: profile combinations with value $U_f = 1,2 \text{ W/m}^2\text{K} - 1,9 \text{ W/m}^2\text{K}$
- » Avantis 70 shi: profile combinations with value $U_f = 0,95 \text{ W/m}^2\text{K} - 1,7 \text{ W/m}^2\text{K}$
(EN ISO 10077-2)

Environment

- » All profiles are easily cleaned
- » Aluminium does not rust, rot or tear and the shape will not deform
- » Aluminium is a "green" product: it can be recycled infinitely without quality loss

Security

- » The combination of safety glass and special hardware such as multipoint locking ensures a high resistance against forced entry. Internal tubular glazing beads prevent unclipping from the outside.
Resistance class ENV 1627 – 1630 class 2
- » A wide range of locking and non-locking handles are integrated in to the system

Design

- » Avantis 70 is compatible within its profile and hardware range, as well as other Sapa Building System products such as our curtain wall and conservatory systems
- » It is available in 2 designs: Classic and Softline
- » Hidden drainage to avoid the requirement for cover caps
- » Doors overlapping, single or double, in- and outward opening
- » A comprehensive range of supplementary finishing profiles allows the fenestration to be integrated perfectly into the building
- » Vent, frame and transom profiles are available in a range of dimensions to meet the needs of stability and design requirements.
- » A wide choice of hinges, handles and hardware finalise your specific needs
- » Designer glazing beads add extra finish



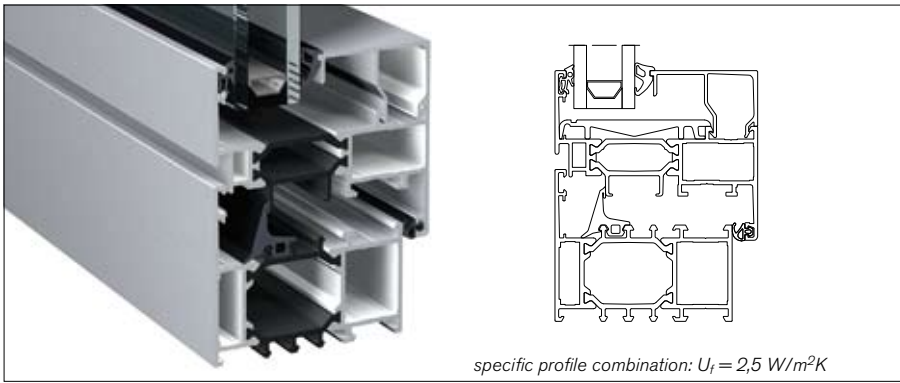

Avantis 70 basic

» $U_f = 1,9 \text{ w/m}^2\text{K} - 2,8 \text{ W/m}^2\text{K}$

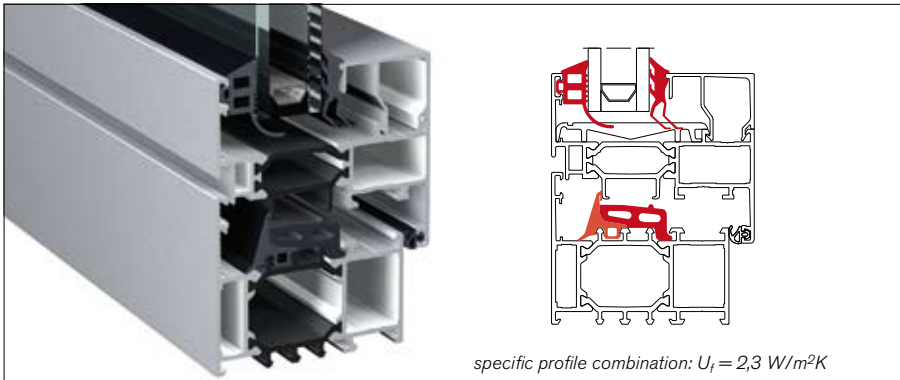

Avantis 70 i

- » $U_f = 1,8 \text{ w/m}^2\text{K} - 2,2 \text{ W/m}^2\text{K}$
- » Improved thermal glazing gaskets
- » Improved thermal central gasket

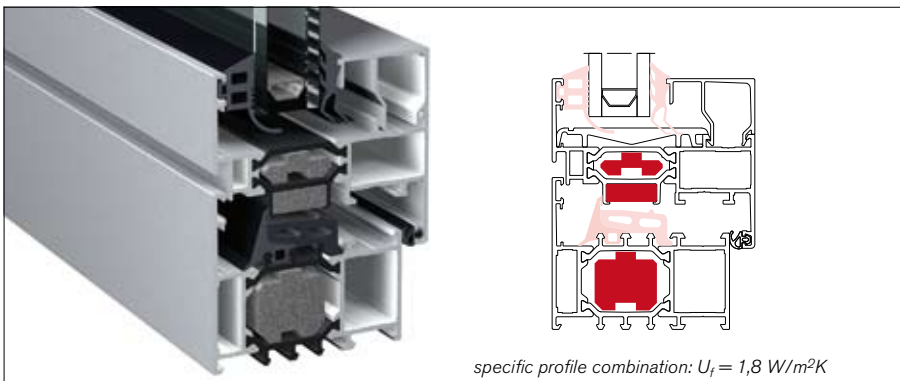

Avantis 70 si

- » $U_f = 1,2 \text{ w/m}^2\text{K} - 1,9 \text{ W/m}^2\text{K}$
- » Improved thermal glazing gaskets & central gasket
- » PE inserts in frame and vent profile
- » PE insert thermal improved rebate

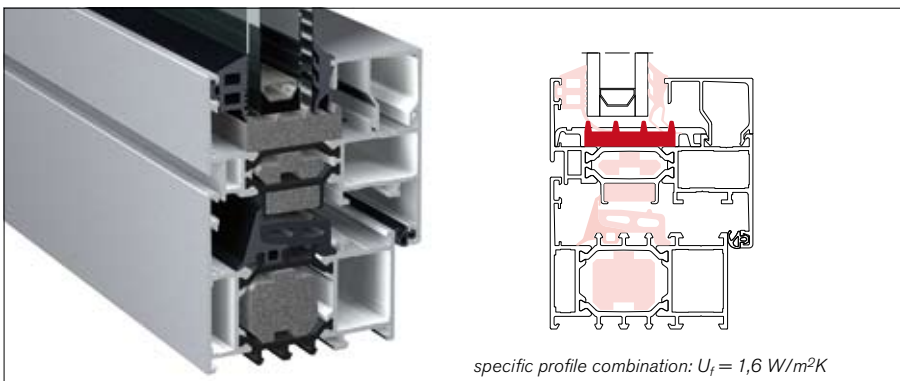

Avantis 70 shi

- » $U_f = 0,95 \text{ w/m}^2\text{K} - 1,7 \text{ W/m}^2\text{K}$
- » Improved thermal glazing gaskets & central gasket
- » PE inserts in frame and vent profile
- » PE insert thermal improved rebate
- » PE insert thermal improved glazing unit

	Avantis 70			
	BASIC	I	SI	SHI
Sightline in mm frame + vent	119	119	119	139
U_{frame}	2,3	2,0	1,6	1,4
$U_{\text{window}} (U_{\text{glazing}} = 1,1)$	≤ 1,6	≤ 1,5	≤ 1,4	≤ 1,3
$U_{\text{window}} (U_{\text{glazing}} = 0,8)$	≤ 1,4	≤ 1,3	≤ 1,2	≤ 1,1

Max. U_w value based on a window surface of $1,6 \text{ m}^2$

Finishes

- » Over 400 powder coated paint colors in matt, gloss or satin.
- » Unique wood effect, textured and textured metallic ranges are available
- » Anodised finish is also an option
- » Accessories can be supplied in corresponding colors to match the profiles
- » The polyamide thermal break allows bi-color finishes. As a result, the exterior building requirements do not infringe the interior design requests.
- » Our surface finishes meet the highest standards of Qualicoat or Qualanod



Performance

- » Avantis 70 includes several weather barriers by means of specially designed gaskets, a large decompression chamber and internal drainage to assure perfect weather resistance.
- » Effective water evacuation is ensured via punched drain holes
- » Special finishing profiles provide additional building drainage
- » Acoustic performance is greatly enhanced with multiple gaskets

Avantis 70 shi

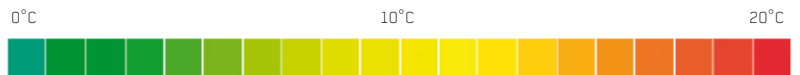
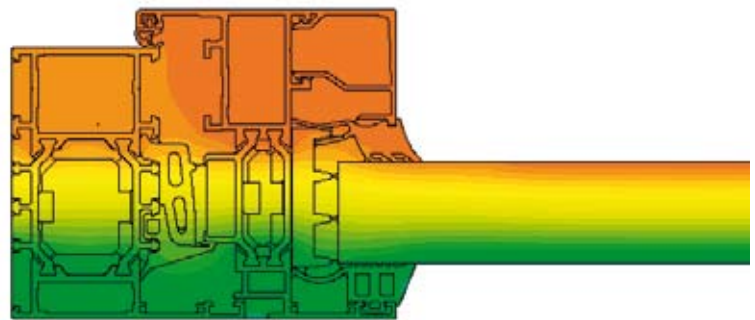







Fabrication

- » Avantis 70 belongs to the Eurosystem range. It is complementary to other Eurosystem series and results in modularity between systems, allowing fabricators to offer maximum service without increasing stock levels
- » The Euronut groove accommodates all standard hardware
- » A wide range of integrated reinforced mullions and transoms, for greater stability on larger spans
- » Three methods of connection are available. Frame and vent use the same corner connector for the Softline design
- » Punching tools specifically designed for the Eurosystem series, ensure fast and accurate assembly
- » Sapa Building System offers its software SapaLogic, an open concept for automation, to fabricators who have a CNC machining center

Project support & service

- » Sapa Building System's experienced Project Team will advise you on the best product solutions
- » We can help you with pricing, strength calculations, building connections, thermal simulations, etc..
- » Specific project solutions can be developed
- » Samples, catalogues, technical specifications and digital drawings are available

SapaLogic is a user-friendly calculation program for fast, efficient and complete calculation of windows, doors, structures, curtain walls and conservatories. SapaLogic is very much complete but modular still: the different versions can be adapted to your company's needs.

SapaThermic is detailed thermal simulation software for doors, windows, sliding systems and curtain walls. It can either be linked to SapaLogic or act as a stand-alone version.

Applications

Windows

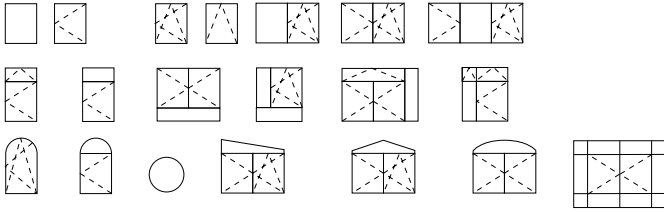

Doors

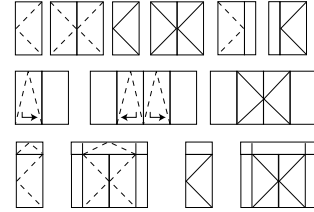

----- : inward opening ——— : outward opening

Dimensions

Min. sightline fixed frame	50 mm
Min. sightline window with inward opening vent	89 mm
Min. sightline window with outward opening vent	99 mm
Min. sightline inward opening door	129 mm
Min. sightline outward opening door	129 mm
Min. sightline transom	72 mm
Profile depth frame / Building depth	70 mm
Profile depth vent	80 mm
Max. window (width x height)	1200 x 2400 mm
Max. door (width x height)	1100 x 2400 mm

Glazing

Rebate height	22 mm
Infill thickness fixed frame	4,5 – 55,5 mm
Infill thickness vent frame	4,5 – 65,5 mm
Glazing method	dry glazed with EPDM gaskets or silicon

Performances

Thermal break	35 mm omega shaped polyamides PA 6.6 GF25		
Thermal insulation	basic:	$U_f = 1,9 - 2,8 \text{ W/m}^2\text{K}$	EN ISO 10077-2
	i:	$U_f = 1,8 - 2,2 \text{ W/m}^2\text{K}$	EN ISO 10077-2
	si:	$U_f = 1,2 - 1,9 \text{ W/m}^2\text{K}$	EN ISO 10077-2
	shi:	$U_f = 0,95 - 1,7 \text{ W/m}^2\text{K}$	EN ISO 10077-2
Air permeability	4	600 Pa	EN 12207
Water tightness	9A	600 Pa	EN 12208
Wind resistance, security test	C3	1200 Pa, security 1800 Pa	EN 12210
Acoustic insulation	$R_w (C;C_{tr}) = 44 \text{ dB} (11,5\text{GH}/20(\text{SF6})/9,5\text{GH})$		EN ISO 717/1

* This information is only an indication. For more information, please consult your local Sapa Building System branch.

Technical drawings

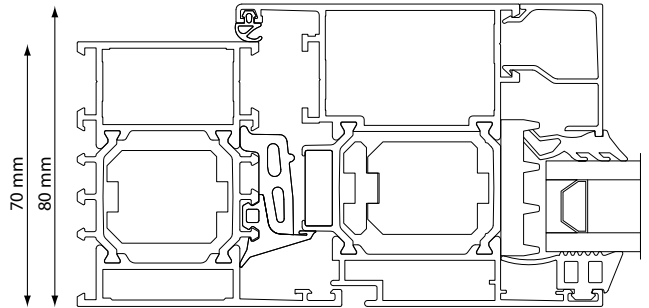
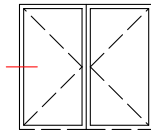
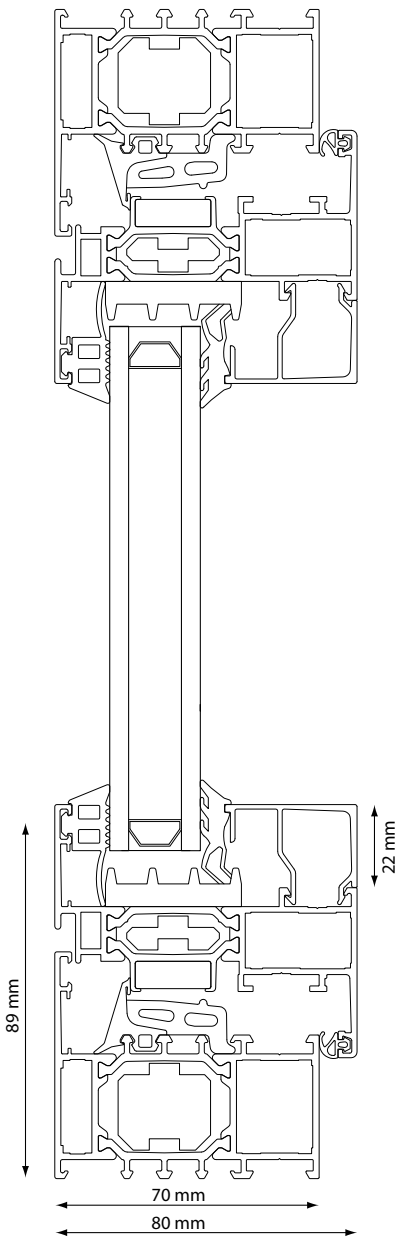
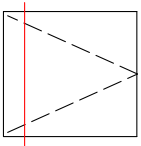

Sapa Building System, is one of the largest suppliers of aluminium building systems in Europe and is part of the Swedish group Sapa. The core business is the development and distribution of aluminium profile systems. Sapa Building System aims for well-developed systems and project solutions offering a tangible added value to fabricators, architects, investors and home-owners.

Windows and Doors

Sliding Systems

Curtain Walls

Conservatories

Balustrades, gates and others

Your local Sapa Building System fabricator

Sapa Building System NV

Postal address **Industrielaan 17, BE-8810 Lichtervelde** Tel. **+32 51 72 96 66** Fax **+32 51 72 96 89**

Postal address **Industriezone Roosveld 11, BE-3400 Landen** Tel. **+32 11 69 03 11** Fax **+32 11 83 20 04**

E-mail **buildingsystem.be@sapagroup.com** Website **www.sapabuildingsystem.be**

sapa: